

2018 PROPOSED BUDGET

A presentation by the Department of Planning
November 16, 2017

Westchester
gov.com

Robert P. Astorino
Westchester County Executive

Program Areas

- Citizen Boards
- Design and Development
- Housing
- Environment
- Land Use



Planning: CITIZEN BOARDS

Provide staff support and guidance

- County Planning Board
- Soil & Water Conservation District Board
- Housing Opportunity Commission
- Stormwater Advisory Board
- Northern Westchester Watershed Committee
- Agriculture and Farmland Protection Board



Planning: DESIGN AND DEVELOPMENT

Administer County's Capital Budget process

- Staff member serves as Executive Secretary to Capital Projects Committee.
- Staff oversees process for submissions.



Planning: DESIGN AND DEVELOPMENT

Prepare reviews of capital project requests

- Charter mandate for Planning Board to review physical impacts of County capital project requests.
- Submit report by September 10.



Planning: DESIGN AND DEVELOPMENT

Design projects and prepare construction plans

- Bikeways and trailways
- Wetland/stream restoration
- Park improvements
- Playgrounds
- Golf course improvements
- Streetscape improvements

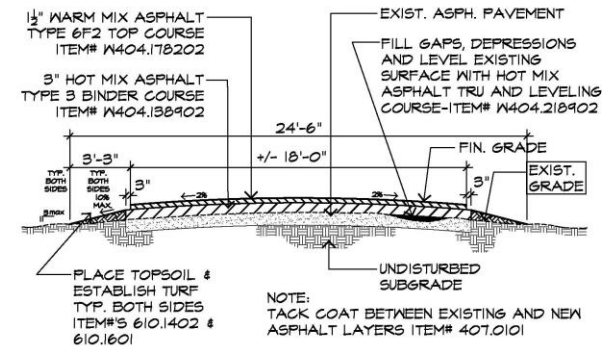
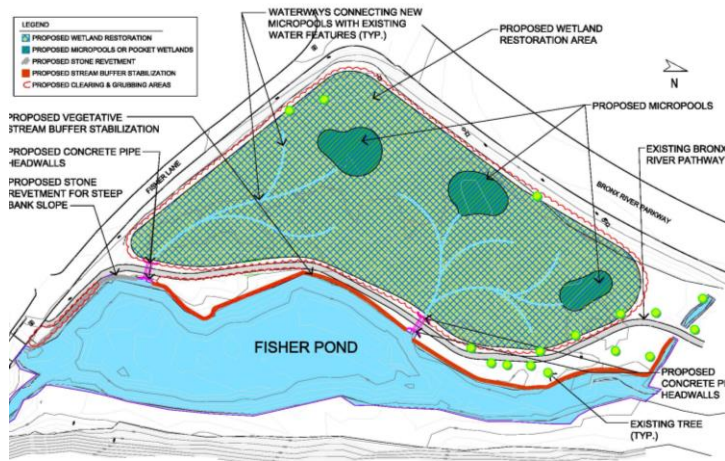

○ FULL DEPTH ASPHALT OVERLAY ON EXISTING PAV'T
 SCALE: HORIZ. 1/4" = 1'-0"
 VERT. 1/2" = 1'-0"

Planning: DESIGN AND DEVELOPMENT

Oversee project implementation



- Bikeways and trailways
- Wetland restorations
- Park improvements
- Playgrounds
- Golf course improvements
- Streetscape improvements



Planning: HOUSING

Manage County role in affordable housing development

- Assistance
 - ✓ Land acquisition
 - ✓ Infrastructure
- Staff reviews and underwrites funding requests.
- County funding to only fill gap needed to assure project viability.



Planning: HOUSING

Follow-through on housing created under the Housing Settlement

- Oversee construction and use of County funding.
- Review marketing efforts and the purchase/occupancy of AFFH units.
- Administer “Homeseeker Central Intake” web site listings and registrants.

Before



After



Planning: HOUSING

Conduct annual housing monitoring

- All housing units provided County funding must be monitored by staff annually for continuing compliance.
- Over 3,717 homes and apartments
 - ✓ 85% rental
 - ✓ 15% home ownership
- Staff reviews rent rolls and occupancy changes.
- Staff inspects condition of units.



Planning: ENVIRONMENT

Prepare documentation of SEQR compliance for all County actions

- NYS Environmental Quality Review Act requires all local agencies to conduct environmental review prior to approving, undertaking or funding certain actions.
- Applies to BOL, A&C, BOH, County departments (*capital projects, local laws, property transactions, sewage district modifications, sanitary code regulations, etc.*).
- Staff reviews over 200 BOL actions per year.
- Staff reviews over 1,000 A&C resolutions per year.

Planning: ENVIRONMENT

Prepare documentation of NEPA compliance

- National Environmental Protection Act requires agencies using federal funds to conduct environmental review prior to approving, undertaking or funding certain actions.
- Staff reviews over 100 actions per year.



Planning: ENVIRONMENT

Flood Mitigation

- Implement Stormwater Management Law
 - Planning chairs and administers County Stormwater Advisory Board
 - Prepare and update, with DPWT, stormwater “reconnaissance” plans
 - Work with municipalities to identify flood mitigation projects eligible for County funding assistance
- Work with federal and state agencies on programs and projects
- Prepare information for municipalities, residents and businesses

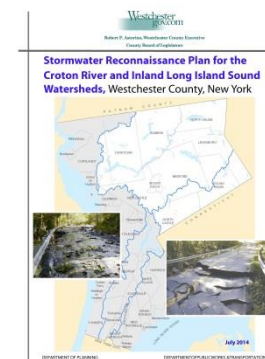
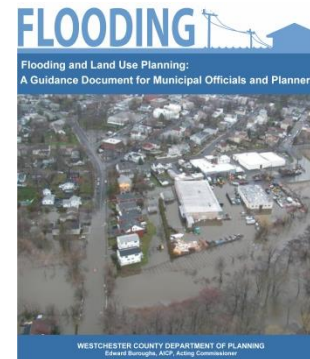
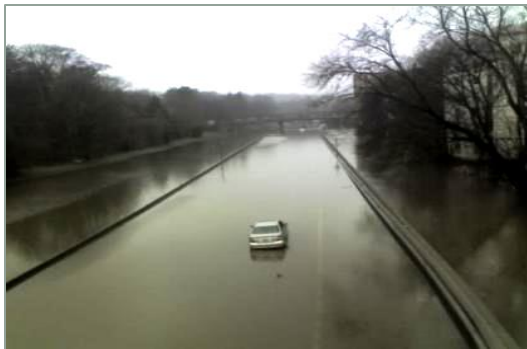

Planning: ENVIRONMENT

Participate in development, implementation and update of Countywide Hazard Mitigation Plan

- Work closely with OEM as a member of steering committee.
- Provide information and outreach on hazard mitigation efforts.
- Assist municipalities to identify funding sources for mitigation projects.
- Prepare and update annual reports for 5-year plan update.

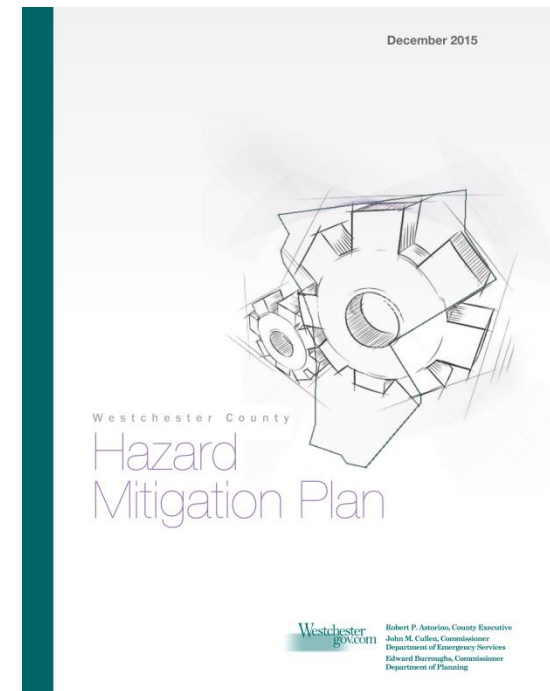

Planning: ENVIRONMENT

Propose, design and oversee stormwater management and restoration projects

- 42 natural resources and stormwater projects completed or under construction.
- County funding leveraged by state and federal grants and appropriations.
- *Primary goals:* manage stormwater to limit flooding and improve water quality.
- *Secondary goals:* improve ecology, aesthetics and passive recreation.
- Projects are models for restoration and stormwater management practices.



Planning: ENVIRONMENT

Coordinate County Depts stormwater MS4 permit compliance

- Coordinate activities among impacted departments.
- Review capital projects for retrofit opportunities.
- Prepare and distribute education and outreach materials.
- Document compliance with MS4 requirements and prepare reports.
- Work with local municipalities on stormwater issues and projects.

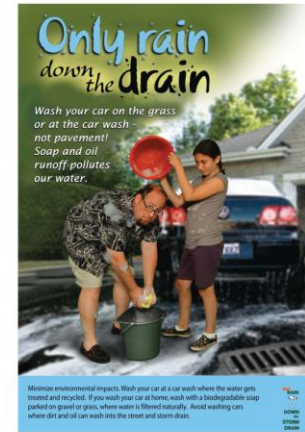
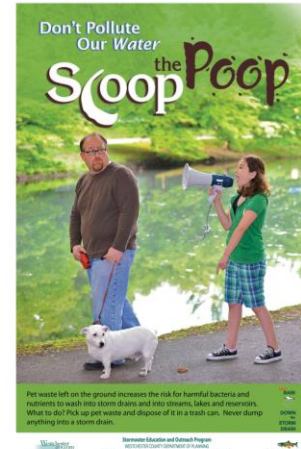

Planning: ENVIRONMENT

Provide staffing for Soil and Water Conservation District

- SWCD receives \$150,000 in state funding annually for conservation-related projects, including stormwater and natural resources management.
- Provides technical soil- and water-related guidance and mandated services to residents and municipalities.
- Develops and presents public education and professional development programs.



Planning: ENVIRONMENT

Oversee parkland acquisition - Westchester Legacy Program

- Implement RiverWalk.
- Identify lands for active recreation.
- Work with local partners to preserve open space.



Planning: ENVIRONMENT

Review other land acquisitions - Farmland Protection

- Assist with administration of agricultural district.
- Review easements and documents associated with purchase of development rights over farmland.

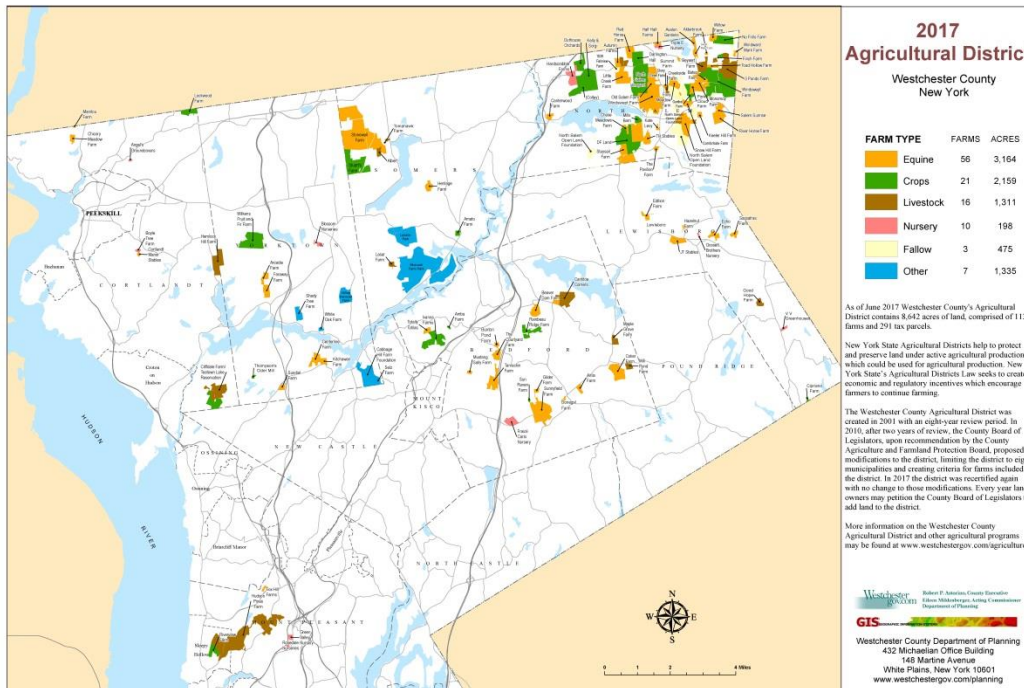

Planning: ENVIRONMENT

Participate in programs of NYC Watershed Memorandum of Agreement

- Signed by 80 governmental agencies and environmental groups in 1997 – including Westchester County and 12 Westchester municipalities (NWWC).
- Watershed Protection and Partnership Programs include the East of Hudson Water Quality Investment Program.



Planning: LAND USE

Serve as Census affiliate and resource for data

- Department is affiliate of State Data Center of NYS Department of Economic Development and Empire State Development.
- Collect and disseminate data to governments, public and media.
- Keep on-line DataBook current.
- Prepare special analysis for other departments and public, tailored to users in the county.

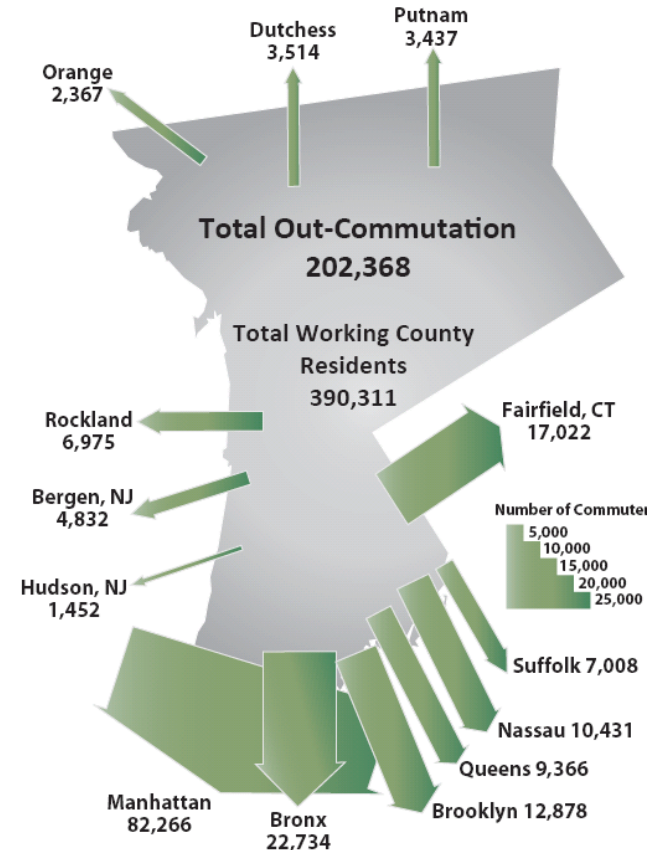

Out-Commutation from Westchester County, 2010
 Source: US Census Bureau LEHD Origin-Destination Employment Statistics, Beginning of Quarter Employment.
 Prepared by the Westchester County Department of Planning.

Planning: LAND USE

Participate in programming with the Westchester Municipal Planning Federation



MUNICIPAL PLANNING PRIMER SERIES

The Planning Board



New Rochelle City Hall



Somers Town House

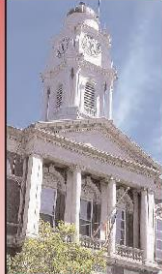

Irvington Village Hall



Mamaroneck Village Hall

Westchester
gov.com

March 2008

Andrew J. Spano, County Executive
County Board of Legislators

Gerard E. Mulligan, AICP, Commissioner
Westchester County Department of Planning



MUNICIPAL PLANNING PRIMER SERIES

The Zoning Board of Appeals



White Plains City Hall



Larchmont Village Hall



North Salem Town House



Ossining Village Hall

Westchester
gov.com

March 2008

Andrew J. Spano, County Executive
County Board of Legislators

Gerard E. Mulligan, AICP, Commissioner
Westchester County Department of Planning



Planning: LAND USE

Participate in transportation planning

- Prepare and provide data to NYMTC (land use, population trends, major development activity, etc.).
- Review and participate in major infrastructure investment studies (Tappan Zee Bridge Replacement, I-287 transit).

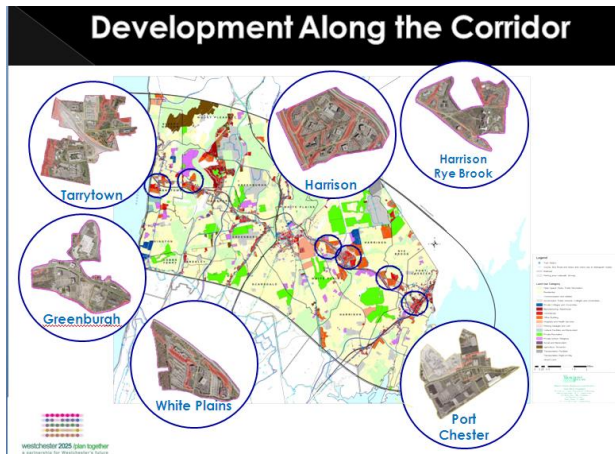

Planning: LAND USE

Westchester 2025: Plan Together

- Promote policies to guide county planning.
- Maintain web-based planning portal.

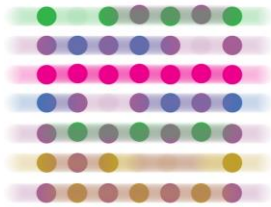
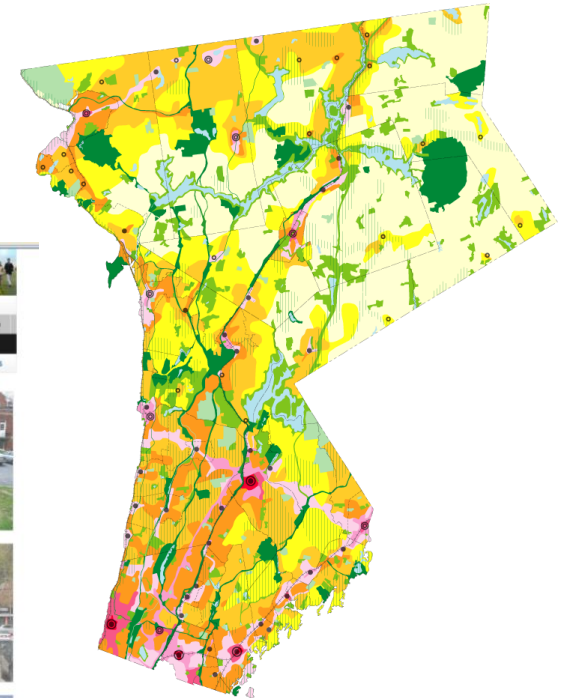

westchester 2025 /plan together
a partnership for Westchester's future

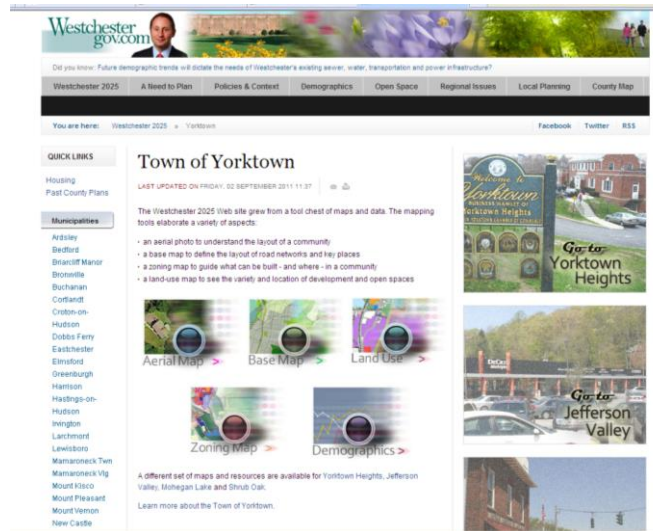

Planning: LAND USE

Provide planning support to municipalities

- Prepare base studies for local Comprehensive Plans.
 - ✓ Completed: Rye Brook, New Castle and North Castle
- Provide special project assistance. In 2018:
 - ✓ Tarrytown comprehensive plan update
 - ✓ Buchanan comprehensive plan update



Village of Rye Brook
Westchester County, New York
PLANNING BASE STUDIES
A detailed study of existing conditions
May 2012

Westchester.gov.com

Robert P. Astorino, Westchester County Executive
County Board of Legislators

Westchester 2025 | plan together
DEPARTMENT OF PLANNING
Edward Bourke, AICP, Commissioner

Department of Planning Operating Budget Summary:

\$3,149,513 tax levy cost

Department of Planning

Operating Budget Summary:

Total Expenditures \$3,833,495

54%

53% Annual salaries (for 21 positions)

1% Materials & Supplies (for department)

46%

24% Contract services (funding pass-through)

22% Inter-departmental charges